

PORTABLE CONCRETE WASHOUT CONTAINER

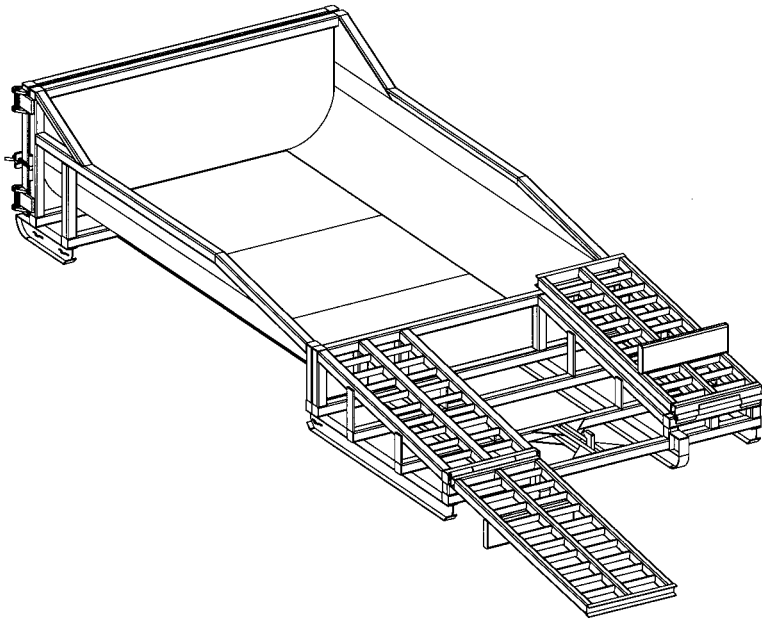

CONCRETE WASHOUT SYSTEMS

PO Box 2604
Carmichael, CA. 95609
Phone: 1.877.292.7468
Fax: 1.916.244.0403
info@concretewashout.com
www.concretewashout.com
Patent Pending

DESCRIPTION

A portable, self-contained and watertight container affixed with ramps that controls, captures and contains caustic concrete wastewater and washout material.

PURPOSE & OBJECTIVE

Allows trade personnel to easily washout concrete trucks, pumps and other equipment associated with cement on site and allows easy off site recycling of the same concrete materials and wastewater.

APPLICATION

Construction projects where concrete, stucco, mortar, grout and cement are used as a construction material or where cementitious wastewater is created.

MAINTENANCE

Inspect and clean out when $\frac{3}{4}$ full, not allowing the container to overflow.

Inspect wastewater level and request a vacuum if needed.

Inspect subcontractors to ensure that proper housekeeping measures are employed when washing out equipment.

SPECIFICATIONS

The container must be portable and temporary, watertight, equipped with ramps and have a holding capacity to accept washout from approximately 350 yards of poured concrete. A vacuum service must accompany washout container and be used by site superintendent as needed. A rampless container may be used in conjunction with a ramped container or by itself if a concrete pump is not needed. The washwater must be disposed of or treated and recycled in an environmentally safe manner and in accordance with federal, state or local regulatory guidelines.

TARGETED POLLUTANTS

Caustic wastewater (high pH level near 12 units)

Suspended solids

Assorted Metals; Chromium VI, Nickel, Sulfate, Potassium, Magnesium and Calcium Compounds